

NOTES:

- NON IMPACT GLAZING OPTIONS:
16 X 9.75 CLEAR OPENING
36.75 X 9.75 CLEAR OPENING
GLAZING SSB (0.090") MINIMUM.
MAY INCLUDE DECORATIVE INSERTS
INSTALLED IN TOP OR INTERMEDIATE SECTION.
NOT AVAILABLE IN MORE THAN ONE SECTION.
DOES NOT SATISFY WINDBORNE-DEBRIS.
- IMPACT GLAZING NOT AVAILABLE.
- VINYL OR WOOD DOOR STOP NAILED A
MAXIMUM OF 6" O.C. MUST OVERLAP TOP AND
BOTH ENDS OF PANELS MINIMUM 7/16" TO
MEET NEGATIVE PRESSURES.
- KEY LOCK, SLIDE LOCKS, OR OPERATOR
REQUIRED.
- LOUVER OPTION - .032" MINIMUM LOUVERS
IN MOLDED FRAMES SCREWED TOGETHER WITH
A MINIMUM OF (10) #8x1" SCREWS INSTALLED
IN THE BOTTOM SECTION. LOUVERS ARE NOT
IMPACT RESISTANT AND DO NOT MEET THE
REQUIREMENTS FOR WIND-BORNE DEBRIS
REGIONS.
- SECTION STEEL TO HAVE A MINIMUM 25 GA
THICKNESS.
- THE DESIGN OF THE SUPPORTING
STRUCTURAL ELEMENTS SHALL BE THE
RESPONSIBILITY OF THE PROFESSIONAL OF
RECORD FOR THE BUILDING OR STRUCTURE AND
IN ACCORDANCE WITH CURRENT BUILDING
CODES FOR THE LOADS LISTED ON THIS
DRAWING.
- DOOR JAMB TO BE GRADE 2 SOUTHERN
PINE. REFER TO JAMB CONNECTION
SUPPLEMENT FOR ATTACHMENT TO SUPPORTING
STRUCTURE.
- FOR LOW HEAD ROOM LIFT CONDITIONS, TOP
BRACKET SHALL BE A 13 GA LHR 7/4 TOP
BRACKET WITH A MINIMUM OF (3) 1/4-14x7/8"
SELF DRILLING CRIMP TITE SCREWS IN LIEU OF
THE BRACKET SHOWN ON THIS DRAWING.
U-BAR ON TOP SECTION SHALL BE INSTALLED
ON TOP OF LHR TOP BRACKETS.

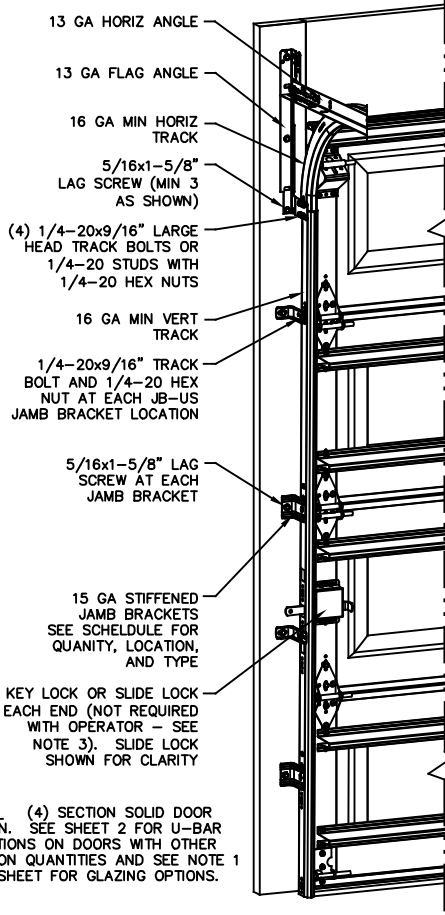

NOTE: (4) SECTION SOLID DOOR SHOWN. SEE SHEET 2 FOR U-BAR LOCATIONS ON DOORS WITH OTHER SECTION QUANTITIES AND SEE NOTE 1 THIS SHEET FOR GLAZING OPTIONS.

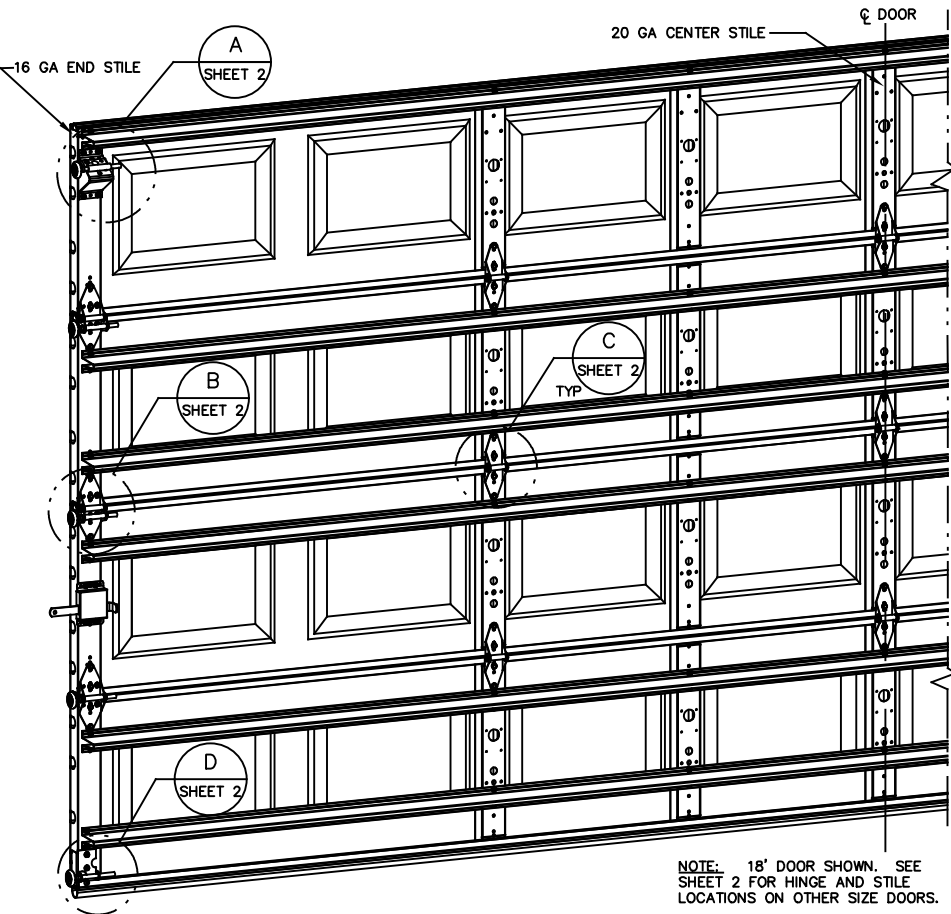

- REVISIONS**
- P1 MODIFIED NOTES TO STATE THAT LOUVERS ARE NOT IMPACT RESISTANT. GRT 6/29/07
 - P2 MODIFIED JAMB BRACKET SCHEDULE ALLOWING REPLACEMENT OF QI WITH JB-US. ADDED MAX GLAZING DIMENSION TO NOTES SHEET 1. ADDED TRACK TO FLAG CONNECTION NOTE. GRT 11/10/07
 - P3 MODIFIED LOUVER OPTION. ADDED TEXAS LICENSE NUMBER TO TITLE BLOCK. GRT 9/19/08
 - P4 UPDATED TITLE BLOCK GRT 4/16/12
 - P5 UPDATED NOTE 1. ESC 11/8/16
 - P6 UPDATED TITLE BLOCK, REV PER ER 31052 ESC 5/31/18
 - P7 UPDATED NOTES ADDED LHR DETAIL ER 31052 ESC 2/12/19
 - REV H ADDED IRC/IBC NOTE TLC 4/12/21

SUPERIMPOSED DESIGN PRESSURE LOADS ON SUPPORTING STRUCTURE

DOOR WIDTH	DOOR HEIGHT	UNIFORM LOAD EACH JAMB (PLF)
17'-0"	ALL	+157.3/-176.0
18'-0"	ALL	+166.5/-186.3

JAMB BRACKET SCHEDULE

DOOR HEIGHT	NO. OF SECTIONS	NO. OF JAMB BRACKETS (EACH JAMB)	TRACK TYPE	LOCATION OF CENTERLINE OF JAMB BRACKETS MEASURED FROM BOTTOM OF TRACK (ALL DIMENSIONS ± 2")
6'-6"	4	4	QI	14" (QI), 34" (JB-US), 44" (QI), 56" (JB-US)
6'-6"	4	4	FAT	10" (JB-US), 25-3/4" (JB-US), 39" (JB-US), 57-1/4" (JB-US)
7'-0"	4	4	QI	14" (QI), 29-1/2" (JB-US), 44" (QI), 63-1/4" (JB-US)
7'-0"	4	4	FAT	10" (JB-US), 29-3/4" (JB-US), 42" (JB-US), 63-1/4" (JB-US)
7'-6"	5	6	QI	2" (JB-US), 14" (QI), 28-1/2" (JB-US), 43" (QI), 62-1/2" (QI), 72" (JB-US)
7'-6"	5	6	FAT	2" (JB-US), 10" (JB-US), 26-3/4" (JB-US), 45" (JB-US), 63" (JB-US), 74-1/2" (JB-US)
8'-0"	5	6	QI	2" (JB-US), 14" (QI), 34" (JB-US), 46" (QI), 58" (JB-US), 66-1/2" (QI)
8'-0"	5	6	FAT	2" (JB-US), 10" (JB-US), 29-3/4" (JB-US), 48" (JB-US), 57-1/2" (JB-US), 77-1/2" (JB-US)
> 8'-0"				SEE NOTE BELOW

NOTE:
(JB-US) FOLLOWING DIMENSION DENOTES SLOTTED JAMB BRACKET ATTACHED TO TRACK WITH 1/4-20x9/16" TRACK BOLT AND NUT.
(QI) FOLLOWING DIMENSION DENOTES QUICK INSTALL JAMB BRACKET INSTALLED IN BUTTERFLY SLOT. NO ADDITIONAL HARDWARE NEEDED TO ATTACH TO TRACK.
ALL DOORS GREATER THAN 8' IN HEIGHT REQUIRE USE OF CONTINUOUS WALL ANGLE. SEE SUPPLEMENT TRACK CHART FOR DETAILS.

COMPLIES WITH THE REQUIREMENTS OF IBC/IRC 2018.



A DIVISION OF OVERHEAD DOOR CORP.
3395 ADDISON DRIVE
PENSACOLA, FLORIDA 32514
(850) 474-9890

STATIC PRESSURE RATINGS		APPROVED SIZES		SCALE: N.T.S.		SIZE: A	
DESIGN (PSF):	+18.50/-20.70	MAX WIDTH:	18'-0"	DATE		NAME	
TEST (PSF):	+27.75/-31.05	MAX HEIGHT:	14'-0"	DRAWN	5/23/06	GRT	
IMPACT/CYCLIC RATED (YES/NO):	NO	MAX SECTION HEIGHT:	21"	CHECKED	4/12/21	TLC	
MODELS 8000/8100/8200				SHEET 1 OF 2			
WINDLOAD SPECIFICATION OPTION CODE 1141				DRAWING PART NO.		REV.	
				327021		H	

JOHN E. SCATES, PE
2560 KING ARTHUR BLVD #124-54
LEWISVILLE, TX 75056
FL PE 51737
TX PE 56308/F2203

PROFESSIONAL ENGINEER'S SEAL PROVIDED ONLY FOR VERIFICATION OF WINDLOAD CONSTRUCTION DETAILS.

13 GA ROLLER SLIDE ATTACHED TO BRACKET WITH 5/16-18 BOLT & NUT IN CENTER SLOT AND 1/4-20x9/16" TRACK BOLT & 1/4-20 HEX NUT THROUGH ANY TWO ALIGNING HOLES

13 GA COMMERCIAL 'A' FRAME TOP BRACKET ATTACHED WITH (4) 1/4-14x7/8" SELF DRILLING CRIMPITITE SCREWS

ADD (2) 1/4-14x7/8" SELF DRILLING CRIMPITITE SCREWS (INSIDE OF EACH END HINGE)

2" NYLON STORMGARD ROLLER WITH 4-1/2" STEM EACH ROLLER LOCATION. OPTIONAL- 11 BALL BEARING NYLON ROLLER.

14 GA WIDE BODY END HINGE ATTACHED WITH (4) 1/4-14x5/8" SELF TAPPING SCREWS

18 GA NARROW BODY INTERMEDIATE HINGE ATTACHED WITH (4) 1/4-14x5/8" SELF TAPPING SCREWS

14 GA BOTTOM BRACKET ATTACHED WITH (2) 1/4-14x7/8" SELF DRILLING CRIMPITITE SCREWS AND (1) 1/4-14x5/8" SELF DRILLING RED SCREW

PLACE 3" U-BAR OVER LOW HEADROOM BRACKET ATTACH THRU END STILE AT EACH END WITH (2) 1/4-14x7/8" SELF DRILLING CRIMPITITE SCREWS.

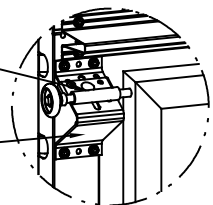

DETAIL A

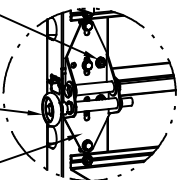

DETAIL B

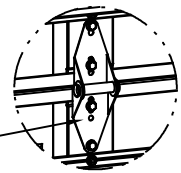

DETAIL C

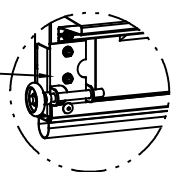

DETAIL D

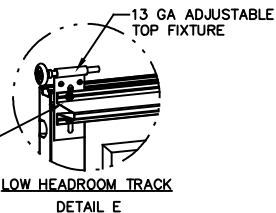

DETAIL E

CENTER STILE & INTERMEDIATE HINGE LOCATIONS

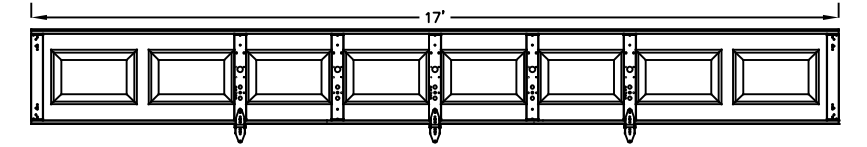
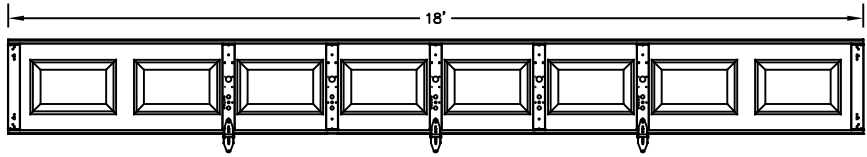

LONG LITE GLAZING LAYOUT

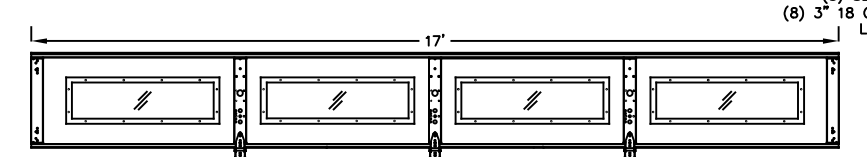
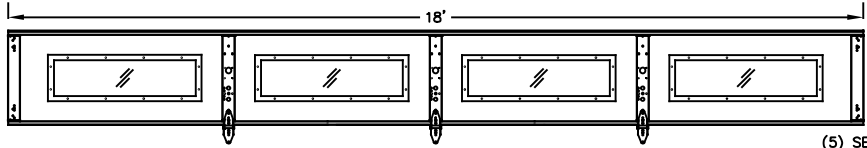

LOUVER - OPTIONAL IN BOTTOM SECTION

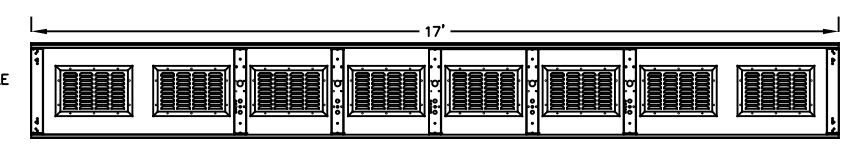
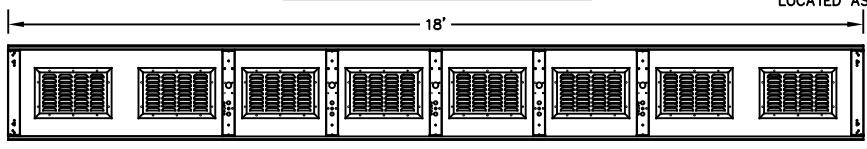

U-BAR LOCATIONS

(8) SECTION DOORS WITH (12) 3" 18 GA 80 KSI U-BARS LOCATED AS SHOWN

(7) SECTION DOORS WITH (11) 3" 18 GA 80 KSI U-BARS LOCATED AS SHOWN

(6) SECTION DOORS WITH (9) 3" 18 GA 80 KSI U-BARS LOCATED AS SHOWN

(5) SECTION DOORS WITH (8) 3" 18 GA 80 KSI U-BARS LOCATED AS SHOWN

(4) SECTION DOORS WITH (6) 3" 18 GA 80 KSI U-BARS LOCATED AS SHOWN

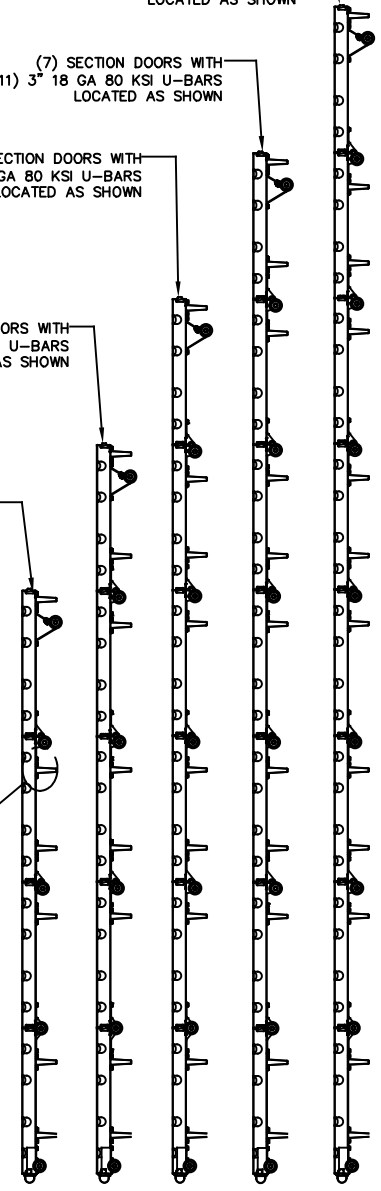

ATTACH U-BAR WITH (2) 1/4-14x7/8" SELF DRILLING CRIMPITITE SCREWS AT EACH STILE LOCATION, TYP.

PROFESSIONAL ENGINEER'S SEAL PROVIDED ONLY FOR VERIFICATION OF WINDLOAD CONSTRUCTION DETAILS.

JOHN E. SCATES, PE
2560 KING ARTHUR BLVD #124-54
LEWISVILLE, TX 75056
FL PE 51737
TX PE 56308/F2203

Wayne Dalton
GARAGE DOORS

A DIVISION OF OVERHEAD DOOR CORP.
3395 ADDISON DRIVE
PENSACOLA, FLORIDA 32514
(850) 474-9890

STATIC PRESSURE RATINGS		APPROVED SIZES	SCALE: N.T.S.	SIZE: A
DESIGN (PSF):	+18.50/-20.70	MAX WIDTH: 18'-0"	DATE	NAME
TEST (PSF):	+27.75/-31.05	MAX HEIGHT: 14'-0"	DRAWN	GRT
IMPACT/CYCLIC RATED (YES/NO):	NO	MAX SECTION HEIGHT: 21"	CHECKED	TLC
MODELS 8000/8100/8200			SHEET 2 OF 2	
WINDLOAD SPECIFICATION OPTION CODE 1141			DRAWING PART NO.	REV.
			327021	H